

Overflow and pressure control valves made of stainless steel, angle-type with threaded connections – externally adjustable –

→ Series 453



■ SUITABLE FOR

Liquids	neutral and non-neutral	
Air, gases and vapours	neutral and non-neutral	
Steam		

■ EXAMPLES OF USE

For the protection of:

- pumps against overloading in closed circuits for neutral / non-neutral, non-sticking liquids

For the control of:

- systems under pressure for neutral/ non-neutral gases and vapours and – depending on the sealing material – also for steam

- chemical plants, biogas plants
- test rig construction
- mechanical engineering and process equipment construction
- shipbuilding industry and marine equipment
- desalination plants
- offshore applications
- secondary areas in the food-, beverage-, pharmaceutical- and cosmetics-industries



■ MATERIAL



■ SPECIFICATION

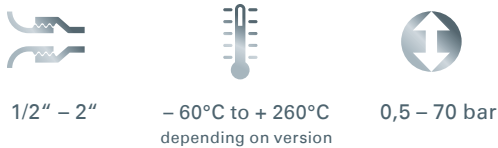

■ APPROVALS

European Pressure Equipment Directive	
TR ZU 032/2013 - TR ZU 010/2011	
Requirements	
PED 2014/68/EU	UK PESR 2016 No. 1105
Classification society	
DNV	DNV
Lloyd's Register EMEA	LR EMEA
American Bureau of Shipping	ABS
Bureau Veritas	BV
Russian Maritime Register of Shipping	RS
Registro Italiano Navale	RINA

■ MATERIALS

Component	Material	DIN EN	ASME
Inlet body	Stainless steel	1.4404	316 L
Outlet body	Stainless steel	1.4408	CF8M
Internal parts	Stainless steel	1.4404	316 L
Bellows	Stainless steel	1.4571	316 Ti
Spring	Stainless steel	1.4310	302

b	with bellows	for neutral and non-neutral media, counter pressure compensated up to 4 bar. Spring, moving parts and the environment are protected from being affected by the medium. With handwheel adjustment Pressure: 0,5 – 25 bar
t	gastight version of spring housing	for neutral and non-neutral media without counter pressure. The environment is protected from being affected by the medium. Only available without lifting device and without hand wheel Pressure: 0,5 – 25 bar
tb	gastight version with bellows	for neutral and non-neutral an particularly for flammable, toxic and environmentally hazardous media and/or counter pressure up to 4 bar. Spring, moving parts and the environment are protected from being affected by the medium. Double gastight. Only available without lifting device and without hand wheel Pressure: 0,5 – 25 bar
k	pressure compensated piston	for neutral and non-neutral media, counter pressure compensated up to 20 bar. Spring, moving parts and the environment are protected from being affected by With handwheel adjustment Pressure: 0,5 – 70 bar

Can be adjusted by hand wheel under operating conditions without medium escaping into the environment.

Valves can be delivered unset within a pressure range or set and sealed at the factory.

■ MEDIUM

GF	gaseous and liquid	Air, vapours, gases, liquids and - depending on safety valve version and seal - also for steam
-----------	--------------------	--

■ TYPE OF LIFTING MECHANISM

K	with twist-type lifting mechanism and sealing cap – not adjustable
O	without lifting device

■ AVAILABLE NOMINAL DIAMETERS AND CONNECTION SIZES

Nominal diameter DN	15	20	25	32		
Inlet	1/2" (15)	3/4" (20)	1" (25)	1 1/4" (32)	1 1/2" (40)	2" (50)
Outlet	1/2" (15)	■				
	3/4" (20)		■			
	1" (25)	■				
	1 1/4" (32)		■			
	1 1/2" (40)			■		
2" (50)				■	■	■

■ TYPE OF CONNECTION INLET / OUTLET THREADED CONNECTIONS

f / f	Standard	Female thread BSP-P / Female thread BSP-P	DIN EN ISO 228-1 / DIN EN ISO 228-1
m / f	On request	Male thread BSP-P / Female thread BSP-P	DIN EN ISO 228-1 / DIN EN ISO 228-1
BSP-Tf / f		Female thread BSP-T / Female thread BSP-P	DIN EN 10226, ISO 7-1 / DIN EN ISO 228-1
BSP-Tm / f		Male thread BSP-T / Female thread BSP-P	DIN EN 10226, ISO 7-1 / DIN EN ISO 228-1

■ SEALS

NBR	Nitrile rubber	Elastomere moulded seal with metallic support up to 25 bar	-30°C to +130°C
EPDM	Ethylene propylene diene	Elastomere moulded seal with metallic support up to 25 bar	-40°C to +170°C
FKM	Fluorocarbon	Elastomere moulded seal with metallic support up to 25 bar	-20°C to +200°C
PTFE	Polytetrafluoroethylene	Flat seal	-60°C to +225°C
FFKM	Perfluorinated rubber	Elastomere moulded seal with metallic support	-10°C to +260°C

■ NOMINAL DIAMETERS, CONNECTIONS, INSTALLATION DIMENSIONS

Series 453: Connection, installation dimensions, ranges of adjustment							
Nominal diameter	DN	15	20	25	32	40	50
Connection DIN EN ISO 228	G	1/2" (15)	3/4" (20)	1" (25)	1 1/4" (32)	1 1/2" (40)	2" (50)
Outlet DIN EN ISO 228	G1	1" (25)	1 1/4" (32)	1 1/2" (40)	2" (50)	2" (50)	2" (50)
Installation dimensions in mm	L	40	43	50	61	61	61
	H / H ¹	102 / 102	156 / 169,5	205 / 223	296 / 318	296 / 318	296 / 318
	H max. / H max. ¹	120 / 120	177 / 190,5	230 / 248,5	320 / 344	320 / 344	320 / 344
	H1 / H1 ¹	76 / 76	139 / 152,5	175 / 193	241 / 263	241 / 263	241 / 263
	H2 / H2 ¹	77 / 77	138 / 151,5	177 / 195	241 / 263	263 / 285	263 / 285
	h	30	39	45	55	69	74
	h1	16	14	19	21	22,5	25,0
	SW1	30	36	46	55	55	70
	SW2	40	50	58	70	70	70
	do	16	18	23	30	30	30
Weight	kg	0,5	1,0	2,0	4,2	4,5	4,7
Set pressure	bar	0,5 - 70	0,5 - 70	0,5 - 70	0,5-70	0,5-70	0,5 - 70
Range of adjustment	bar	0,5-0,9	0,5-1	0,5-0,9	0,5-0,9	0,5-0,9	0,5-0,9
		1-1,3	1-1,6	0,9-1,5	1-1,3	1-1,3	1-1,3
		1,3-2,9	1,6-2,8	1,5-2	1,4-3	1,4-3	1,4-3
		2,9-3,9	2,8-5,3	2,1-4,5	3,1-5,5	3,1-5,5	3,1-5,5
		3,9-7,9	5,4-10	4,6-8	5,6-11	5,6-11	5,6-11
		8-11,5	10-12	8,1-14	11-16	11-16	11-16
		11-16	12-25	14-25	16-25	16-25	16-25
		16-25	25-45	25-50	25-40	25-40	25-40
	25-40	45-70	50-70	40-70	40-70	40-70	

¹Dimension for the version with bellows

■ MAIN DIMENSIONS, INSTALLATION DIMENSIONS

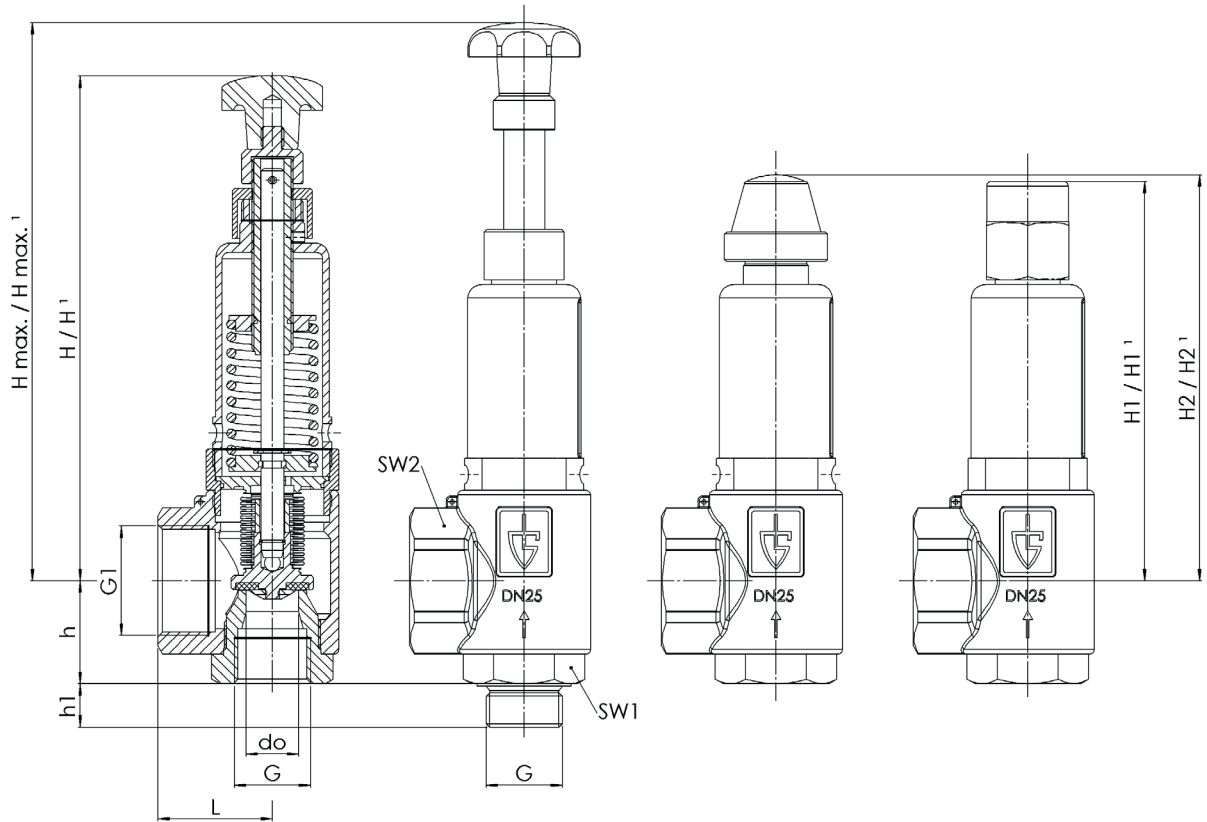

Series	Valve version	Medium	Lifting device	Nominal diameter DN	Connection type		Connection size		Seal	Options	Set pressure	Quantity
					Inlet	Outlet	Inlet	Outlet				
453	<i>b</i>	GF	<i>O</i>	25	<i>m</i>	<i>f</i>	25	40	FKM		7,5	2
453	<i>b</i>	GF	<i>K</i>	32	<i>f</i>	<i>f</i>	40	50	FFKM		3,1 - 5,5	1
453												
453												

■ PROPERTIES

GOX	Especially for gaseous O2 applications by employment of specific materials including oil- and grease free production process	<input type="checkbox"/>	<input type="checkbox"/>
P01	Oil- and grease-free production	<input type="checkbox"/>	<input type="checkbox"/>
		<input type="checkbox"/>	<input type="checkbox"/>

■ CERTIFICATES / APPROVALS

C01	Factory certificate acc. DIN EN 10204 2.2 (WKZ 2.2)	<input type="checkbox"/>	C06	ATEX evaluation acc. to 2014/34/EU	<input type="checkbox"/>
C02-1	Test certificate acc. DIN EN 10204 3.1 (WPZ 3.1) for non TÜV-CE valves marking of individual serial number is required	<input type="checkbox"/>	C07	SIL evaluation relating to IEC 61508-2	<input type="checkbox"/>
C03	Material test certificate acc. DIN EN 10204 3.1 (MPZ 3.1) (pressure retaining part)	<input type="checkbox"/>	C10	Certificate of oil- and grease free production	<input type="checkbox"/>
C05	Sealing material Manufacturer certification (FDA, USP 3, 3-A,...), Please indicate description of certificate:	<input type="checkbox"/>	C11	Certification of the production process especially for gaseous oxygen applications by employment of specific materials	<input type="checkbox"/>

■ ADMISSIONS / ACCREDITATIONS

AA1	EC Type examination acc. to Directive 2014/68/EU	<input type="checkbox"/>	AK1	Det Norske Veritas (DNV) type approval	<input type="checkbox"/>
AA4	EAC - certificate/declaration with passport for the valve and laser marking of the valve	<input type="checkbox"/>	AK2	Lloyd's Register (LR) type approval	<input type="checkbox"/>
		<input type="checkbox"/>	AK3	American Bureau of Shipping (ABS) type approval	<input type="checkbox"/>
		<input type="checkbox"/>	AK4	Bureau Veritas (BV) type approval	<input type="checkbox"/>
		<input type="checkbox"/>	AK5	Russian Maritime Register of Shipping (RMRS) type approval	<input type="checkbox"/>
		<input type="checkbox"/>	AK6	Registro Italiano Navale (RINA) type approval	<input type="checkbox"/>
		<input type="checkbox"/>	AL	Individual inspection by notified body inspector – (body to be indicated):	<input type="checkbox"/>

■ ENQUIRY

Copy and send to: order@goetze.de.

■ CAPACITY TABLE

Series 453: <10bar, at 1bar overpressure ≥10bar, at 10% overpressure													
Nominal diameters DN		15 + 15/15 + 20/20			20			25			32		
Set pressure bar		I	II	III	I	II	III	I	II	III	I	II	III
Air I	0,5	120	97	4,4	275	212	8,6	503	387	13,6	844	649	23,3
	1,0	105	81	4,8	309	238	9,2	592	455	14,7	1009	776	26,9
Nm³/h	1,5	126	87	4,4	332	255	8,8	697	536	15,1	1190	915	27,7
	2,0	134	84	4,6	375	288	9,3	836	643	16,3	1380	1062	29,5
Steam II	2,5	139	90	4,8	408	314	9,7	821	632	16,1	1518	1168	30,8
	3,0	120	97	5,1	370	285	8,5	964	742	16,7	1665	1281	32,0
kg/h	3,5	139	108	5,2	423	325	8,9	1057	813	17,9	1523	1172	27,1
	4,0	90	69	3,3	481	370	9,6	1108	852	18,5	1609	1238	27,6
Water III	4,5	93	73	3,4	512	394	9,8	1221	939	19,8	1712	1317	28,7
	5,0	101	76	3,5	530	408	10,1	815	627	16,4	1786	1374	29,6
m³/h	5,5	104	78	3,6	425	327	8,0	912	702	17,3	1842	1417	31,1
	6,0	106	81	3,7	459	353	8,6	1023	787	18,0	1406	1082	25,0
	6,5	109	83	3,7	478	368	9,3	1120	862	18,8	1491	1147	25,7
	7,0	122	85	3,8	501	385	9,8	1254	965	19,7	1598	1229	26,6
	7,5	129	91	3,9	547	421	10,4	1388	1068	20,8	1721	1324	27,5
	8,0	142	101	3,6	587	452	11,2	1514	1165	21,7	1825	1404	28,2
	8,5	141	105	3,4	604	465	11,8	1246	958	18,2	1927	1482	29,3
	9,0	140	109	3,2	621	478	12,5	1278	983	18,7	2034	1565	30,1
	9,5	139	115	2,9	643	495	13,2	1386	1066	19,4	2110	1623	31,3
	10,0	112	84	1,7	394	294	6,2	848	633	15,7	1472	1098	25,5
	11,0	122	91	1,7	430	320	6,5	926	691	16,4	1607	1199	26,6
	12,0	133	99	1,8	466	347	6,8	1004	749	17,1	1742	1299	27,7
	13,0	143	107	1,9	354	264	5,5	1081	807	17,7	1877	1400	24,2
	14,0	153	114	2,0	380	283	5,7	835	623	18,3	2011	1501	25,0
	15,0	163	122	2,0	405	302	5,9	891	664	18,9	2146	1601	25,9
	16,0	174	130	2,1	431	321	6,1	947	706	19,5	1551	1157	26,7
	17,0	184	137	2,2	456	340	6,2	1003	748	20,1	1643	1226	27,4
	18,0	194	145	2,2	482	359	6,4	1059	790	20,6	1735	1294	28,2
	19,0	204	153	2,3	507	378	6,6	1115	831	21,2	1827	1363	28,9
	20,0	215	160	2,3	532	397	6,8	1171	873	21,7	1918	1431	29,6
	25,0	266	198	2,6	660	492	7,6	1450	1082	24,2	2377	1773	33,0
	26,0	276	206	2,7	400	298	3,9	586	437	17,6	1017	758	22,0
	27,0	287	214	2,7	415	309	3,9	608	453	17,9	1054	787	22,4
	28,0	297	221	2,8	429	320	4,0	629	469	18,2	1092	815	22,8
	29,0	307	229	2,8	444	331	4,1	651	486	18,5	1130	843	23,2
	30,0	317	236	2,9	459	342	4,1	673	501	18,8	1168	869	23,6
	32,0	338	251	3,0	489	364	4,3	716	533	19,4	1243	925	24,3
	34,0	358	267	3,1	519	386	4,4	760	566	20,0	1319	981	25,1
	36,0	379	282	3,1	548	408	4,5	804	598	20,6	1394	1038	25,8
	38,0	400	297	3,2	578	430	4,7	847	630	21,1	1470	1094	26,5
	40,0	420	313	3,3	608	452	4,8	891	663	21,7	1545	1150	27,1
	42,0	441	328	3,4	637	474	4,9	934	695	22,2	1621	1206	27,8
	44,0	461	343	3,5	667	497	5,0	978	728	22,7	1697	1263	28,4
	40,0	420	313	3,3	608	453	4,8	891	663	21,7	1545	1151	27,1
	45,0	471	351	3,5	682	508	5,1	999	744	23,0	1734	1292	28,8
	50,0	523	390	3,7	756	563	5,4	1108	826	24,2	1923	1433	30,3
	55,0	574	428	3,9	830	619	5,6	1217	907	25,3	2112	1574	31,7
	60,0	626	466	4,1	905	674	5,9	1326	988	26,5	2301	1714	33,1
	65,0	677	504	4,2	979	729	6,1	1435	1069	27,5	2490	1855	34,5
	70,0	728	543	4,4	1053	785	6,3	1544	1150	28,5	2679	1996	35,7

Performance values apply up to a back pressure of 50%.